



Owner Manual

Field Roller (FR)



IMPORTANT: Read all instructions before using this attachment

Congratulations on the purchase of your new attachment!

Before you get started, we have provided a helpful space to jot down a few important details:

Model number: FR5 / FR6

Serial number:

Date of purchase:

Factory reference: FR

This manual should be considered a permanent part of this attachment and therefore should remain with it even if the attachment is subsequently sold.

The manufacturer continually seeks advancements in its product design and quality. Therefore, while this manual contains the most current product information available at the time of printing, there may be minor discrepancies between your attachment and this manual.

If you have any questions concerning this manual, please consult your local dealer.

Safety Information

Before installation/maintenance, ensure the tractor/ATV and attachment are stationary with the hydraulic lift system in a neutral position, and the ignition key removed. Read and understand this manual fully before operating machinery. Failure to follow all safety standards can result in severe injury or death.

1. Regularly check condition of both tractor/ATV and attachment.
2. Regularly check/tighten all bolts, nuts and screws.
3. Never consume alcohol/drugs while operating machinery.
4. Grader Blades and Tipping Transport Boxes are for use with compact tractors only, within the power range specified, and at the recommended speed at all times.
5. Reduce the speed when working on hillsides/rough terrain.
6. Only use for the indicated purpose. Do not use to transport personnel or livestock.
7. Always wear protective gloves, ear and eye protection and tie back long hair. Do not wear loose clothing.
8. Always check the immediate area is clear before operating.
9. Keep spectators at a safe distance.
10. Do not run the engine in an enclosed area.
11. Do not leave the machine unattended while operating.
12. Do not touch moving parts.
13. Stop if excessive noise or vibration occurs.
14. When travelling with the implement installed on a tractor, keep the PTO turned off and the attachment in a transport position.
15. Ensure the engine on the tractor/ATV is switched off before any maintenance. Be aware components can be hot after operation.
16. Pay attention to any sharp/pointed parts when servicing.
17. Always repair/replace any defective parts.
18. Do not modify the attachment in any way as this may impair the operation and overall safety.
19. Ensure all safety guards are in place and in good condition.
20. Keep all safety signs clean and legible. Replace missing/illegible signs.

Safety Information (continued)

Attachment Pre-use Checks

Upon receipt of your new attachment and again within the first 4 hours of use (the 'shake in' period), we recommend the following:

1. Check/tighten all bolts, nuts and screws.
2. Check the tension of any belt(s), and adjust if required.
3. Apply grease to grease points if required.
4. Check gear oil level, top-up if required but do not overfill.

Be aware components can be hot after operation.

Tractor Pre-use Checks

1. Check the attachment is properly attached to the tractor. Ensure secure pins are used on the linkage mounting pins.
2. Add extra weights to the front of the tractor (or wheel weights) if required.
3. Check the tractor PTO turns freely, and the attachment's PTO drive shaft can extend sufficiently. Apply grease to the PTO drive shaft.
4. Frequently check the condition of the chain on the PTO drive shaft. Keep all universal joints and protective parts in a good condition.
5. Before installing, the tractor and attachment should be stationary, remove the key from the ignition.
6. Install and secure all safety guards, doors and covers before operating.
7. Bystanders should leave the immediate area before connecting the drive from the tractor.

Post-use Regular Checks

1. Check any wearing parts. Ensure they are not damaged and components are secure in their mounts. Repair or replace as required.
2. Clean the attachment, and check for/clear any entangled material around any moving parts.

Contents

Safety Information.....	page 2-3
Important Information.....	page 5
Parts Diagram.....	page 6

Important Information

The roller is designed to be used with either an agricultural tractor or ATV and should not be used with any other type of vehicle.

The roller is fabricated from mild steel and finished with a protective painted coat.

The steel drum axle rotates on a pair of greased bearings mounted inside the supporting frame. Apply grease to the grease points regularly to avoid the bearings seizing.

Water Filling

The steel drum has a fill/drain plug for the water ballast used to increase overall roller weight.

During the winter months it is essential to either drain any water from the roller drum or add anti-freeze solution.

An anti-freeze solution will avoid metal fatigue if the water ballast freezes and expands. Please follow all directions on the anti-freeze container and dispose of in the correct manner.

Scraper Bar

To reduce material and debris build up on the roller an adjustable scraper bar is located at the rear of the roller.

If you find there is too much debris on the roller adjust the scraper bar to give a smaller gap between the roller drum. If the scraper is getting clogged up when the roller is in use increase the scraper bar clearance.

Parts Diagram

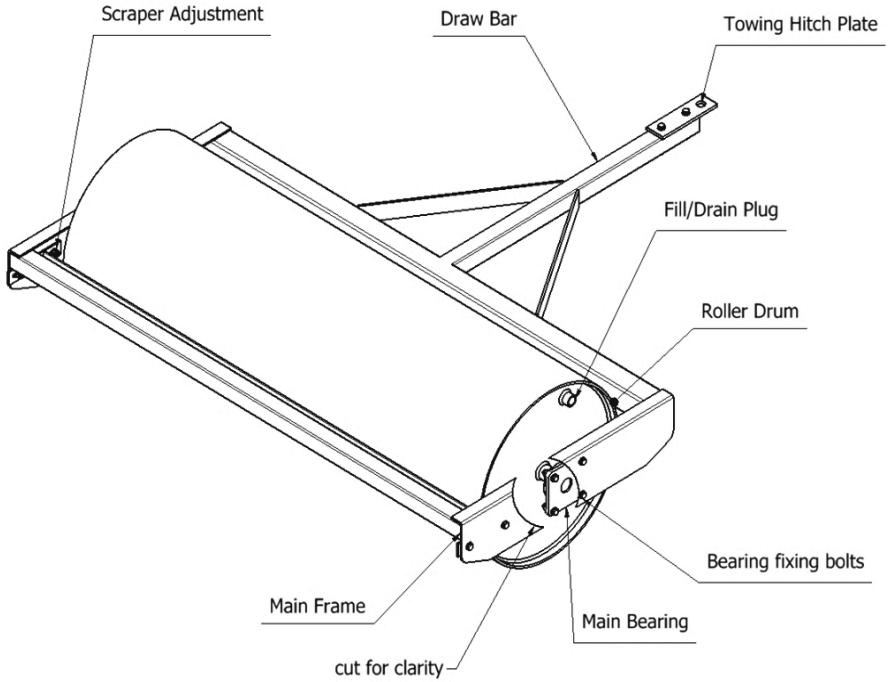



First published: May 2021